

LEX & YACC

by Tom Niemann

epaperpress.com

Contents

Contents	2
Preface	3
Introduction	4
Lex	6
Theory	6
Practice	7
Yacc	11
Theory	11
Practice, Part I.....	12
Practice, Part II.....	15
Calculator.....	18
Description	18
Include File	21
Lex Input	22
Yacc Input	23
Interpreter.....	27
Compiler.....	28
Graph	30
More Lex.....	34
Strings	34
Reserved Words	34
Debugging Lex.....	35
More Yacc.....	36
Recursion	36
If-Else Ambiguity	37
Error Messages.....	38
Inherited Attributes	39
Embedded Actions	39
Debugging Yacc.....	40
Bibliography	41

Preface

This document explains how to construct a compiler using lex and yacc. Lex and yacc are tools used to generate lexical analyzers and parsers. I assume you can program in C and understand data structures such as linked-lists and trees.

The introduction describes the basic building blocks of a compiler and explains the interaction between lex and yacc. The next two sections describe lex and yacc in more detail. With this background we can construct a sophisticated calculator. Conventional arithmetic operations and control statements, such as **if-else** and **while**, are implemented. With minor changes we will convert the calculator into a compiler for a stack-based machine. The remaining sections discuss issues that commonly arise in compiler writing. Source code for examples may be downloaded from the web site listed below.

Permission to reproduce portions of this document is given provided the web site listed below is referenced. No additional restrictions apply. Source code, when part of a software project, may be used freely without reference to the author and is available at the following web site.

Tom Niemann
Portland, Oregon
epaperpress.com/lexandyacc

Introduction

Before 1975 writing a compiler was a very time-consuming process. Then Lesk [1975] and Johnson [1975] published papers on lex and yacc. These utilities greatly simplify compiler writing. Implementation details for lex and yacc may be found in Aho [2006]. Flex and bison, clones for lex and yacc, can be obtained for free from [GNU](#) and [Cygwin](#).

Cygwin is a 32-bit Windows ports of the GNU software. In fact Cygwin is a port of the Unix operating system to Windows and comes with compilers gcc and g++. To install simply download and run the setup executable. Under devel install bison, flex, gcc-g++, gdb, and make. Under **editors** install vim. Lately I've been using flex and bison under the Cygwin environment.

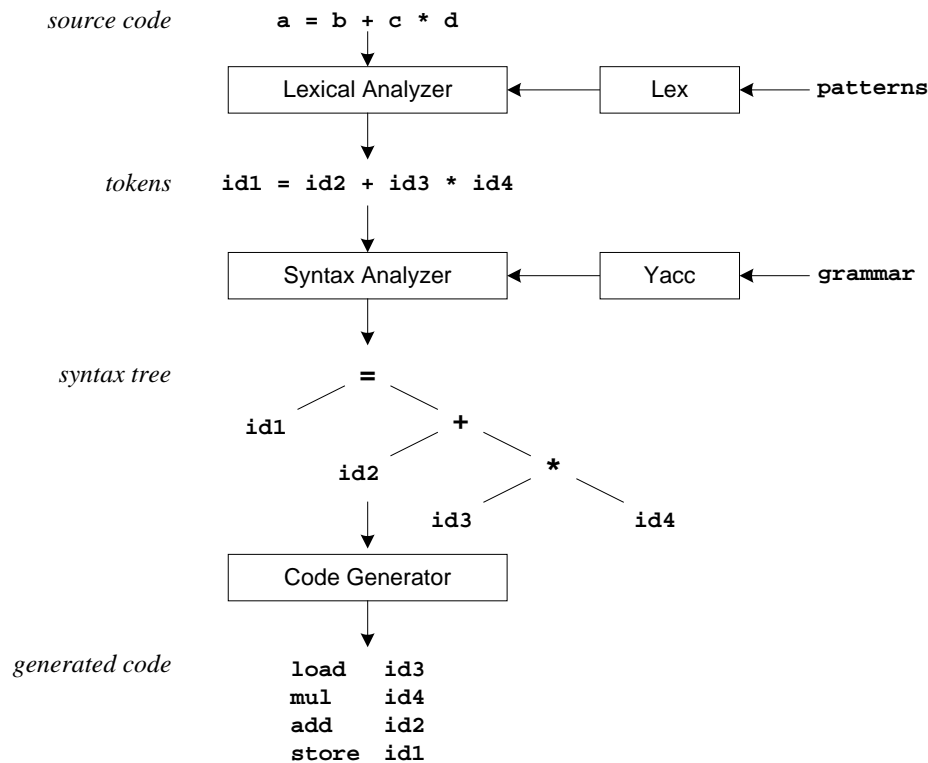

Figure 1: Compilation Sequence

The **patterns** in the above diagram is a file you create with a text editor. Lex will read your patterns and generate C code for a lexical analyzer or scanner. The lexical analyzer matches strings in the input, based on your patterns, and converts the strings to tokens. Tokens are numerical representations of strings, and simplify processing.

When the lexical analyzer finds identifiers in the input stream it enters them in a symbol table. The symbol table may also contain other information such as data type (integer or real) and location of each variable in memory. All subsequent references to identifiers refer to the appropriate symbol table index.

The grammar in the above diagram is a text file you create with a text editor. Yacc will read your grammar and generate C code for a syntax analyzer or parser. The syntax analyzer uses grammar rules that allow it to analyze tokens from the lexical analyzer and create a syntax tree. The syntax tree imposes a hierarchical structure the tokens. For example, operator precedence and associativity are apparent in the syntax tree. The next step, code generation, does a depth-first

walk of the syntax tree to generate code. Some compilers produce machine code, while others, as shown above, output assembly language.

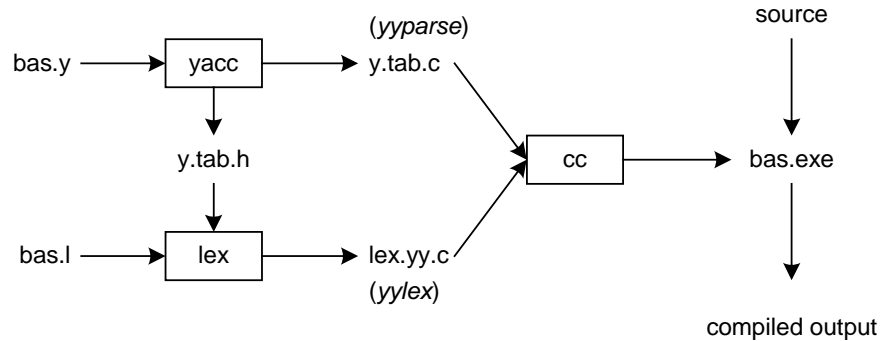

Figure 2: Building a Compiler with Lex/Yacc

Figure 2 illustrates the file naming conventions used by lex & yacc. We'll assume our goal is to write a BASIC compiler. First, we need to specify all pattern matching rules for lex (bas.l) and grammar rules for yacc (bas.y). Commands to create our compiler, bas.exe, are listed below:

```

yacc -d bas.y           # create y.tab.h, y.tab.c
lex bas.l              # create lex.yy.c
cc lex.yy.c y.tab.c -obas.exe # compile/link
  
```

Yacc reads the grammar descriptions in bas.y and generates a syntax analyzer (parser), that includes function **yyparse**, in file y.tab.c. Included in file bas.y are token declarations. The `-d` option causes yacc to generate definitions for tokens and place them in file y.tab.h. Lex reads the pattern descriptions in bas.l, includes file y.tab.h, and generates a lexical analyzer, that includes function **yylex**, in file lex.yy.c.

Finally, the lexer and parser are compiled and linked together to create executable bas.exe. From **main** we call **yyparse** to run the compiler. Function **yyparse** automatically calls **yylex** to obtain each token.

Lex

Theory

During the first phase the compiler reads the input and converts strings in the source to tokens. With regular expressions we can specify patterns to lex so it can generate code that will allow it to scan and match strings in the input. Each pattern specified in the input to lex has an associated action. Typically an action returns a token that represents the matched string for subsequent use by the parser. Initially we will simply print the matched string rather than return a token value.

The following represents a simple pattern, composed of a regular expression, that scans for identifiers. Lex will read this pattern and produce C code for a lexical analyzer that scans for identifiers.

```
letter(letter|digit)*
```

This pattern matches a string of characters that begins with a single letter followed by zero or more letters or digits. This example nicely illustrates operations allowed in regular expressions:

- repetition, expressed by the "*" operator
- alternation, expressed by the "|" operator
- concatenation

Any regular expression expressions may be expressed as a finite state automaton (FSA). We can represent an FSA using states, and transitions between states. There is one start state and one or more final or accepting states.

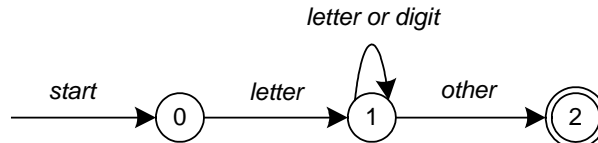

Figure 3: Finite State Automaton

In Figure 3 state 0 is the start state and state 2 is the accepting state. As characters are read we make a transition from one state to another. When the first letter is read we transition to state 1. We remain in state 1 as more letters or digits are read. When we read a character other than a letter or digit we transition to accepting state 2. Any FSA may be expressed as a computer program. For example, our 3-state machine is easily programmed:

```
start: goto state0  
  
state0: read c  
        if c = letter goto statel  
        goto state0  
  
statel: read c  
        if c = letter goto statel  
        if c = digit goto statel  
        goto state2  
  
state2: accept string
```

This is the technique used by lex. Regular expressions are translated by lex to a computer program that mimics an FSA. Using the next *input* character and *current state* the next state is easily determined by indexing into a computer-generated state table.

Now we can easily understand some of lex's limitations. For example, lex cannot be used to recognize nested structures such as parentheses. Nested structures are handled by incorporating a stack. Whenever we encounter a "(" we push it on the stack. When a ")" is encountered we match it with the top of the stack and pop the stack. However lex only has states and transitions between states. Since it has no stack it is not well suited for parsing nested structures. Yacc augments an FSA with a stack and can process constructs such as parentheses with ease. The important thing is to use the right tool for the job. Lex is good at pattern matching. Yacc is appropriate for more challenging tasks.

Practice

Pattern	Matches
.	any character except newline
\.	literal .
\n	newline
\t	tab
^	beginning of line
\$	end of line

Table 1: Special Characters

Pattern	Matches
?	zero or one copy of the preceding expression
*	zero or more copies of the preceding expression
+	one or more copies of the preceding expression
a b	a or b
(ab)+	one or more copies of ab (grouping)
"a+b"	literal "a+b" (C escapes still work)
abc	abc
abc*	ab abc abcc abccc ...
"abc*"	literal abc*
abc+	abc abcc abccc ...
a(bc)+	abc abc bc abc bc bc ...
a(bc)?	a abc

Table 2: Operators

Pattern	Matches
[abc]	one of: a b c
[a-z]	any letter a-z
[a\ -z]	one of: a - z
[-az]	one of: - a z
[A-Za-z0-9]+	one or more alphanumeric characters
[\t\n]+	whitespace
[^ab]	anything except: a b
[a^b]	one of: a ^ b
[a b]	one of: a b

Table 3: Character Class

Regular expressions are used for pattern matching. A character class defines a single character and normal operators lose their meaning. Two operators allowed in a character class are the hyphen (“-”) and circumflex (“^”). When used between two characters the hyphen represents a range of characters. The circumflex, when used as the first character, negates the expression. If two patterns match the same string, the longest match wins. In case both matches are the same length, then the first pattern listed is used.

```
... definitions ...
%%
... rules ...
%%
... subroutines ...
```

Input to Lex is divided into three sections with %% dividing the sections. This is best illustrated by example. The first example is the shortest possible lex file:

```
%%
```

Input is copied to output one character at a time. The first %% is always required, as there must always be a rules section. However if we don't specify any rules then the default action is to match everything and copy it to output. Defaults for input and output are **stdin** and **stdout**, respectively. Here is the same example with defaults explicitly coded:

```
%%
/* match everything except newline */
. ECHO;
/* match newline */
\n ECHO;
%%

int yywrap(void) {
    return 1;
}

int main(void) {
    yylex();
    return 0;
}
```

Two patterns have been specified in the rules section. Each pattern must begin in column one. This is followed by whitespace (space, tab or newline) and an optional action associated with the pattern. The action may be a single C statement, or multiple C statements, enclosed in braces. Anything not starting in column one is copied verbatim to the generated C file. We may take advantage of this behavior to specify comments in our lex file. In this example there are two patterns, "." and "\n", with an **ECHO** action associated for each pattern. Several macros and variables are predefined by lex. **ECHO** is a macro that writes code matched by the pattern. This is the default action for any unmatched strings. Typically, **ECHO** is defined as:

```
#define ECHO fwrite(yytext, yyleng, 1, yyout)
```

Variable **yytext** is a pointer to the matched string (NULL-terminated) and **yyleng** is the length of the matched string. Variable **yyout** is the output file and defaults to stdout. Function **yywrap** is called by lex when input is exhausted. Return 1 if you are done or 0 if more processing is required. Every C program requires a **main** function. In this case we simply call **yylex** that is the main entry-point for lex. Some implementations of lex include copies of **main** and **yywrap** in a library thus eliminating the need to code them explicitly. This is why our first example, the shortest lex program, functioned properly.

Name	Function
int yylex(void)	call to invoke lexer, returns token
char *yytext	pointer to matched string
yyleng	length of matched string
yylval	value associated with token
int yywrap(void)	wrapup, return 1 if done, 0 if not done
FILE *yyout	output file
FILE *yyin	input file
INITIAL	initial start condition
BEGIN	condition switch start condition
ECHO	write matched string

Table 4: Lex Predefined Variables

Here is a program that does nothing at all. All input is matched but no action is associated with any pattern so there will be no output.

```
%%
.
\n
```

The following example prepends line numbers to each line in a file. Some implementations of lex predefine and calculate **yylineno**. The input file for lex is **yyin** and defaults to **stdin**.

```
%{
    int yylineno;
}%
%%
^(.*)\n    printf("%4d\t%s", ++yylineno, yytext);
%%
int main(int argc, char *argv[]) {
    yyin = fopen(argv[1], "r");
    yylex();
    fclose(yyin);
}
```

The definitions section is composed of substitutions, code, and start states. Code in the definitions section is simply copied as-is to the top of the generated C file and must be bracketed with “%{” and “%}” markers. Substitutions simplify pattern-matching rules. For example, we may define digits and letters:

```

digit    [0-9]
letter   [A-Za-z]
%{
    int count;
%}
%%
    /* match identifier */
{letter}({letter}|{digit})*      count++;
%%
int main(void) {
    yylex();
    printf("number of identifiers = %d\n", count);
    return 0;
}

```

Whitespace must separate the defining term and the associated expression. References to substitutions in the rules section are surrounded by braces (**{letter}**) to distinguish them from literals. When we have a match in the rules section the associated C code is executed. Here is a scanner that counts the number of characters, words, and lines in a file (similar to Unix wc):

```

%{
    int nchar, nword, nline;
%}
%%
\n      { nline++; nchar++; }
[^ \t\n]+ { nword++, nchar += yyleng; }
.       { nchar++; }
%%
int main(void) {
    yylex();
    printf("%d\t%d\t%d\n", nchar, nword, nline);
    return 0;
}

```

Yacc

Theory

Grammars for yacc are described using a variant of Backus Naur Form (BNF). This technique, pioneered by John Backus and Peter Naur, was used to describe ALGOL60. A BNF grammar can be used to express *context-free* languages. Most constructs in modern programming languages can be represented in BNF. For example, the grammar for an expression that multiplies and adds numbers is

```
E -> E + E
E -> E * E
E -> id
```

Three productions have been specified. Terms that appear on the left-hand side (lhs) of a production, such as **E** (expression) are nonterminals. Terms such as **id** (identifier) are terminals (tokens returned by lex) and only appear on the right-hand side (rhs) of a production. This grammar specifies that an expression may be the sum of two expressions, the product of two expressions, or an identifier. We can use this grammar to generate expressions:

```
E -> E * E      (r2)
-> E * z        (r3)
-> E + E * z    (r1)
-> E + y * z    (r3)
-> x + y * z    (r3)
```

At each step we expanded a term and replace the lhs of a production with the corresponding rhs. The numbers on the right indicate which rule applied. To parse an expression we need to do the reverse operation. Instead of starting with a single nonterminal (start symbol) and generating an expression from a grammar we need to reduce an expression to a single nonterminal. This is known as *bottom-up* or *shift-reduce* parsing and uses a stack for storing terms. Here is the same derivation but in reverse order:

```
1   . x + y * z    shift
2   x . + y * z    reduce(r3)
3   E . + y * z    shift
4   E + . y * z    shift
5   E + y . * z    reduce(r3)
6   E + E . * z    shift
7   E + E * . z    shift
8   E + E * z .    reduce(r3)
9   E + E * E .    reduce(r2)    emit multiply
10  E + E .        reduce(r1)    emit add
11  E .            accept
```

Terms to the left of the dot are on the stack while remaining input is to the right of the dot. We start by shifting tokens onto the stack. When the top of the stack matches the rhs of a production we replace the matched tokens on the stack with the lhs of the production. In other words the matched tokens of the rhs are popped off the stack, and the lhs of the production is pushed on the stack. The matched tokens are known as a *handle* and we are *reducing* the handle to the lhs of the production. This process continues until we have shifted all input to the stack and only the starting nonterminal remains on the stack. In step 1 we shift the **x** to the stack. Step 2 applies rule r3 to the stack to change **x** to **E**. We continue shifting and reducing until a single nonterminal, the start symbol, remains in the stack. In step 9, when we reduce rule r2, we emit the multiply instruction.

Similarly the add instruction is emitted in step 10. Consequently multiply has a higher precedence than addition.

Consider the shift at step 6. Instead of shifting we could have reduced and apply rule r1. This would result in addition having a higher precedence than multiplication. This is known as a *shift-reduce* conflict. Our grammar is *ambiguous* because there is more than one possible derivation that will yield the expression. In this case operator precedence is affected. As another example, associativity in the rule

```
E -> E + E
```

is ambiguous, for we may recurse on the left or the right. To remedy the situation, we could rewrite the grammar or supply yacc with directives that indicate which operator has precedence. The latter method is simpler and will be demonstrated in the practice section.

The following grammar has a *reduce-reduce* conflict. With an **id** on the stack we may reduce to **T**, or **E**.

```
E -> T
E -> id
T -> id
```

Yacc takes a default action when there is a conflict. For shift-reduce conflicts yacc will shift. For reduce-reduce conflicts it will use the first rule in the listing. It also issues a warning message whenever a conflict exists. The warnings may be suppressed by making the grammar unambiguous. Several methods for removing ambiguity will be presented in subsequent sections.

Practice, Part I

```
... definitions ...
%%
... rules ...
%%
... subroutines ...
```

Input to yacc is divided into three sections. The definitions section consists of token declarations and C code bracketed by "%{" and "%}". The BNF grammar is placed in the rules section and user subroutines are added in the subroutines section.

This is best illustrated by constructing a small calculator that can add and subtract numbers. We'll begin by examining the linkage between lex and yacc. Here is the definitions section for the yacc input file:

```
%token INTEGER
```

This definition declares an **INTEGER** token. Yacc generates a parser in file **y.tab.c** and an include file, **y.tab.h**:

```
#ifndef YYSTYPE
#define YYSTYPE int
#endif
#define INTEGER 258
extern YYSTYPE yylval;
```

Lex includes this file and utilizes the definitions for token values. To obtain tokens yacc calls **yylex**. Function **yylex** has a return type of int that returns a token. Values associated with the token are returned by lex in variable **yyval**. For example,

```
[0-9]+    {
           yyval = atoi(yytext);
           return INTEGER;
        }
```

would store the value of the integer in **yyval**, and return token **INTEGER** to yacc. The type of **yyval** is determined by **YYSTYPE**. Since the default type is integer this works well in this case. Token values 0-255 are reserved for character values. For example, if you had a rule such as

```
[-+]      return *yytext;      /* return operator */
```

the character value for minus or plus is returned. Note that we placed the minus sign first so that it wouldn't be mistaken for a range designator. Generated token values typically start around 258 because lex reserves several values for end-of-file and error processing. Here is the complete lex input specification for our calculator:

```
%{
#include <stdlib.h>
void yyerror(char *);
#include "y.tab.h"
%}

%%

[0-9]+    {
           yyval = atoi(yytext);
           return INTEGER;
        }

[-+\n]    return *yytext;

[ \t]     ; /* skip whitespace */

.         yyerror("invalid character");

%%

int yywrap(void) {
    return 1;
}
```

Internally yacc maintains two stacks in memory; a parse stack and a value stack. The parse stack contains terminals and nonterminals that represent the current parsing state. The value stack is an array of **YYSTYPE** elements and associates a value with each element in the parse stack. For example when lex returns an **INTEGER** token yacc shifts this token to the parse stack. At the same time the corresponding **yyval** is shifted to the value stack. The parse and value stacks are always synchronized so finding a value related to a token on the stack is easily accomplished. Here is the yacc input specification for our calculator:

```

%{
    #include <stdio.h>
    int yylex(void);
    void yyerror(char *);
%}

%token INTEGER

%%

program:
    program expr '\n'          { printf("%d\n", $2); }
    ;

expr:
    INTEGER                    { $$ = $1; }
    | expr '+' expr            { $$ = $1 + $3; }
    | expr '-' expr            { $$ = $1 - $3; }
    ;

%%

void yyerror(char *s) {
    fprintf(stderr, "%s\n", s);
}

int main(void) {
    yyparse();
    return 0;
}

```

The rules section resembles the BNF grammar discussed earlier. The left-hand side of a production, or nonterminal, is entered left-justified and followed by a colon. This is followed by the right-hand side of the production. Actions associated with a rule are entered in braces.

With left-recursion, we have specified that a program consists of zero or more expressions. Each expression terminates with a newline. When a newline is detected we print the value of the expression. When we apply the rule

```

expr: expr '+' expr          { $$ = $1 + $3; }

```

we replace the right-hand side of the production in the parse stack with the left-hand side of the same production. In this case we pop “**expr '+' expr**” and push “**expr**”. We have reduced the stack by popping three terms off the stack and pushing back one term. We may reference positions in the value stack in our C code by specifying “**\$1**” for the first term on the right-hand side of the production, “**\$2**” for the second, and so on. “**\$\$**” designates the top of the stack after reduction has taken place. The above action adds the value associated with two expressions, pops three terms off the value stack, and pushes back a single sum. As a consequence the parse and value stacks remain synchronized.

Numeric values are initially entered on the stack when we reduce from **INTEGER** to **expr**. After **INTEGER** is shifted to the stack we apply the rule

```
expr: INTEGER      { $$ = $1; }
```

The **INTEGER** token is popped off the parse stack followed by a push of **expr**. For the value stack we pop the integer value off the stack and then push it back on again. In other words we do nothing. In fact this is the default action and need not be specified. Finally, when a newline is encountered, the value associated with **expr** is printed.

In the event of syntax errors yacc calls the user-supplied function **yyerror**. If you need to modify the interface to **yyerror** then alter the canned file that yacc includes to fit your needs. The last function in our yacc specification is **main** ... in case you were wondering where it was. This example still has an ambiguous grammar. Although yacc will issue shift-reduce warnings it will still process the grammar using shift as the default operation.

Practice, Part II

In this section we will extend the calculator from the previous section to incorporate some new functionality. New features include arithmetic operators multiply and divide. Parentheses may be used to over-ride operator precedence, and single-character variables may be specified in assignment statements. The following illustrates sample input and calculator output:

```
user: 3 * (4 + 5)
calc: 27
user: x = 3 * (4 + 5)
user: y = 5
user: x
calc: 27
user: y
calc: 5
user: x + 2*y
calc: 37
```

The lexical analyzer returns **VARIABLE** and **INTEGER** tokens. For variables **yylval** specifies an index to the symbol table **sym**. For this program **sym** merely holds the value of the associated variable. When **INTEGER** tokens are returned, **yylval** contains the number scanned. Here is the input specification for lex:

```
%{
    #include <stdlib.h>
    void yyerror(char *);
    #include "y.tab.h"
}%

%%

    /* variables */
[a-z]      {
            yyval = *yytext - 'a';
            return VARIABLE;
        }

    /* integers */
[0-9]+     {
            yyval = atoi(yytext);
            return INTEGER;
        }

    /* operators */
[-+()=/*\n] { return *yytext; }

    /* skip whitespace */
[ \t]      ;

    /* anything else is an error */
.          yyerror("invalid character");

%%

int yywrap(void) {
    return 1;
}
```

The input specification for yacc follows. The tokens for **INTEGER** and **VARIABLE** are utilized by yacc to create **#defines** in **y.tab.h** for use in lex. This is followed by definitions for the arithmetic operators. We may specify **%left**, for left-associative or **%right** for right associative. The last definition listed has the highest precedence. Consequently multiplication and division have higher precedence than addition and subtraction. All four operators are left-associative. Using this simple technique we are able to disambiguate our grammar.

```

%token INTEGER VARIABLE
%left '+' '-'
%left '*' '/'

%{
    void yyerror(char *);
    int yylex(void);
    int sym[26];
%}

%%

program:
    program statement '\n'
    |
    ;

statement:
    expr                                { printf("%d\n", $1); }
    | VARIABLE '=' expr                { sym[$1] = $3; }
    ;

expr:
    INTEGER
    | VARIABLE                          { $$ = sym[$1]; }
    | expr '+' expr                     { $$ = $1 + $3; }
    | expr '-' expr                     { $$ = $1 - $3; }
    | expr '*' expr                     { $$ = $1 * $3; }
    | expr '/' expr                     { $$ = $1 / $3; }
    | '(' expr ')'                       { $$ = $2; }
    ;

%%

void yyerror(char *s) {
    fprintf(stderr, "%s\n", s);
    return 0;
}

int main(void) {
    yyparse();
    return 0;
}

```

Calculator

Description

This version of the calculator is substantially more complex than previous versions. Major changes include control constructs such as **if-else** and **while**. In addition a syntax tree is constructed during parsing. After parsing we walk the syntax tree to produce output. Three versions of the tree walk routine are supplied:

- an interpreter that executes statements during the tree walk
- a compiler that generates code for a hypothetical stack-based machine
- a version that generates a syntax tree of the original program

To make things more concrete, here is a sample program,

```
x = 0;
while (x < 3) {
    print x;
    x = x + 1;
}
```

with output for the interpretive version,

```
0
1
2
```

an output for the compiler version,

```
    push    0
    pop     x
L000:
    push    x
    push    3
    compLT
    jz     L001
    push    x
    print
    push    x
    push    1
    add
    pop     x
    jmp    L000
L001:
```

Constants, variables, and nodes can be represented by **yyval** in the parser's value stack. A more accurate representation of decimal integers is given below. This is similar to C/C++ where integers that begin with 0 are classified as octal.

```
0      {
        yyival.iValue = atoi(yytext);
        return INTEGER;
      }

[1-9][0-9]* {
        yyival.iValue = atoi(yytext);
        return INTEGER;
      }
```

Notice the type definitions

```
%token <iValue> INTEGER
%type <nPtr> expr
```

This binds **expr** to **nPtr**, and **INTEGER** to **iValue** in the **YYSTYPE** union. This is required so that yacc can generate the correct code. For example, the rule

```
expr: INTEGER { $$ = con($1); }
```

should generate the following code. Note that **yyvsp[0]** addresses the top of the value stack, or the value associated with **INTEGER**.

```
yyval.nPtr = con(yyvsp[0].iValue);
```

The unary minus operator is given higher priority than binary operators as follows:

```
%left GE LE EQ NE '>' '<'
%left '+' '-'
%left '*' '/'
%nonassoc UMINUS
```

The **%nonassoc** indicates no associativity is implied. It is frequently used in conjunction with **%prec** to specify precedence of a rule. Thus, we have

```
expr: '-' expr %prec UMINUS { $$ = node(UMINUS, 1, $2); }
```

indicating that the precedence of the rule is the same as the precedence of token **UMINUS**. And **UMINUS** (as defined above) has higher precedence than the other operators. A similar technique is used to remove ambiguity associated with the if-else statement (see If-Else Ambiguity).

The syntax tree is constructed bottom-up allocating the leaf nodes when variables and integers are reduced. When operators are encountered a node is allocated and pointers to previously allocated nodes are entered as operands.

After the tree is built function **ex** is called to do a depth-first walk of the syntax tree. A depth-first walk visits nodes in the order that they were originally allocated. This results in operators being applied in the order that they were encountered during parsing. Three versions of **ex** are included: an interpretive version, a compiler version, and a version that generates a syntax tree.

Include File

```
typedef enum { typeCon, typeId, typeOpr } nodeEnum;

/* constants */
typedef struct {
    int value; /* value of constant */
} conNodeType;

/* identifiers */
typedef struct {
    int i; /* subscript to sym array */
} idNodeType;

/* operators */
typedef struct {
    int oper; /* operator */
    int nops; /* number of operands */
    struct nodeTypeTag *op[1]; /* operands, extended at runtime */
} oprNodeType;

typedef struct nodeTypeTag {
    nodeEnum type; /* type of node */

    union {
        conNodeType con; /* constants */
        idNodeType id; /* identifiers */
        oprNodeType opr; /* operators */
    };
} nodeType;

extern int sym[26];
```

Lex Input

```
%{
#include <stdlib.h>
#include "calc3.h"
#include "y.tab.h"
void yyerror(char *);
}%

%%

[a-z]      {
            yyval.sIndex = *yytext - 'a';
            return VARIABLE;
          }

0          {
            yyval.iValue = atoi(yytext);
            return INTEGER;
          }

[1-9][0-9]* {
            yyval.iValue = atoi(yytext);
            return INTEGER;
          }

[-()<>=+*/;{}.] {
            return *yytext;
          }

">="      return GE;
"<="      return LE;
"=="      return EQ;
"!="      return NE;
"while"   return WHILE;
"if"      return IF;
"else"    return ELSE;
"print"   return PRINT;

[ \t\n]+  ;          /*ignore whitespace */

.         yyerror("Unknown character");
%%
int yywrap(void) {
    return 1;
}
```

Yacc Input

```
%{
#include <stdio.h>
#include <stdlib.h>
#include <stdarg.h>
#include "calc3.h"

/* prototypes */
nodeType *opr(int oper, int nops, ...);
nodeType *id(int i);
nodeType *con(int value);
void freeNode(nodeType *p);
int ex(nodeType *p);
int yylex(void);

void yyerror(char *s);
int sym[26];          /* symbol table */
%}

%union {
    int iValue;          /* integer value */
    char sIndex;        /* symbol table index */
    nodeType *nPtr;     /* node pointer */
};

%token <iValue> INTEGER
%token <sIndex> VARIABLE
%token WHILE IF PRINT
%nonassoc IFX
%nonassoc ELSE

%left GE LE EQ NE '>' '<'
%left '+' '-'
%left '*' '/'
%nonassoc UMINUS

%type <nPtr> stmt expr stmt_list
```

```

%%

program:
    function                { exit(0); }
    ;

function:
    function stmt          { ex($2); freeNode($2); }
    | /* NULL */
    ;

stmt:
    ';'                    { $$ = opr(';', 2, NULL, NULL); }
    | expr ';'            { $$ = $1; }
    | PRINT expr ';'      { $$ = opr(PRINT, 1, $2); }
    | VARIABLE '=' expr ';' { $$ = opr('=', 2, id($1), $3); }
    | WHILE '(' expr ')' stmt { $$ = opr(WHILE, 2, $3, $5); }
    | IF '(' expr ')' stmt %prec IFX { $$ = opr(IF, 2, $3, $5); }
    | IF '(' expr ')' stmt ELSE stmt
    | '{' stmt_list '}'   { $$ = opr(IF, 3, $3, $5, $7); }
    | '{' stmt_list '}'   { $$ = $2; }
    ;

stmt_list:
    stmt                    { $$ = $1; }
    | stmt_list stmt      { $$ = opr(';', 2, $1, $2); }
    ;

expr:
    INTEGER                { $$ = con($1); }
    | VARIABLE            { $$ = id($1); }
    | '-' expr %prec UMINUS { $$ = opr(UMINUS, 1, $2); }
    | expr '+' expr       { $$ = opr('+', 2, $1, $3); }
    | expr '-' expr       { $$ = opr('-', 2, $1, $3); }
    | expr '*' expr       { $$ = opr('*', 2, $1, $3); }
    | expr '/' expr       { $$ = opr('/', 2, $1, $3); }
    | expr '<' expr       { $$ = opr('<', 2, $1, $3); }
    | expr '>' expr       { $$ = opr('>', 2, $1, $3); }
    | expr GE expr        { $$ = opr(GE, 2, $1, $3); }
    | expr LE expr        { $$ = opr(LE, 2, $1, $3); }
    | expr NE expr        { $$ = opr(NE, 2, $1, $3); }
    | expr EQ expr        { $$ = opr(EQ, 2, $1, $3); }
    | '(' expr ')'        { $$ = $2; }
    ;

```



```

%%

#define SIZEOF_NODETYPE ((char *)&p->con - (char *)p)

nodeType *con(int value) {
    nodeType *p;

    /* allocate node */
    if ((p = malloc(sizeof(nodeType))) == NULL)
        yyerror("out of memory");

    /* copy information */
    p->type = typeCon;
    p->con.value = value;

    return p;
}

nodeType *id(int i) {
    nodeType *p;

    /* allocate node */
    if ((p = malloc(sizeof(nodeType))) == NULL)
        yyerror("out of memory");

    /* copy information */
    p->type = typeId;
    p->id.i = i;

    return p;
}

```

```

nodeType *opr(int oper, int nops, ...) {
    va_list ap;
    nodeType *p;
    int i;

    /* allocate node, extending op array */
    if ((p = malloc(sizeof(nodeType) +
        (nops-1) * sizeof(nodeType *))) == NULL)
        yyerror("out of memory");

    /* copy information */
    p->type = typeOpr;
    p->opr.oper = oper;
    p->opr.nops = nops;
    va_start(ap, nops);
    for (i = 0; i < nops; i++)
        p->opr.op[i] = va_arg(ap, nodeType*);
    va_end(ap);
    return p;
}

void freeNode(nodeType *p) {
    int i;

    if (!p) return;
    if (p->type == typeOpr) {
        for (i = 0; i < p->opr.nops; i++)
            freeNode(p->opr.op[i]);
    }
    free (p);
}

void yyerror(char *s) {
    fprintf(stdout, "%s\n", s);
}

int main(void) {
    yyparse();
    return 0;
}

```

Interpreter

```
#include <stdio.h>
#include "calc3.h"
#include "y.tab.h"

int ex(nodeType *p) {
    if (!p) return 0;
    switch(p->type) {
        case typeCon:      return p->con.value;
        case typeId:       return sym[p->id.i];
        case typeOpr:
            switch(p->opr.oper) {
                case WHILE: while(ex(p->opr.op[0]))
                            ex(p->opr.op[1]);
                            return 0;
                case IF:    if (ex(p->opr.op[0]))
                            ex(p->opr.op[1]);
                            else if (p->opr.nops > 2)
                                ex(p->opr.op[2]);
                            return 0;
                case PRINT: printf("%d\n", ex(p->opr.op[0]));
                            return 0;
                case ';':   ex(p->opr.op[0]); return ex(p->opr.op[1]);
                case '=':   return sym[p->opr.op[0]->id.i] =
                            ex(p->opr.op[1]);
                case UMINUS: return -ex(p->opr.op[0]);
                case '+':   return ex(p->opr.op[0]) + ex(p->opr.op[1]);
                case '-':   return ex(p->opr.op[0]) - ex(p->opr.op[1]);
                case '*':   return ex(p->opr.op[0]) * ex(p->opr.op[1]);
                case '/':   return ex(p->opr.op[0]) / ex(p->opr.op[1]);
                case '<':   return ex(p->opr.op[0]) < ex(p->opr.op[1]);
                case '>':   return ex(p->opr.op[0]) > ex(p->opr.op[1]);
                case GE:    return ex(p->opr.op[0]) >= ex(p->opr.op[1]);
                case LE:    return ex(p->opr.op[0]) <= ex(p->opr.op[1]);
                case NE:    return ex(p->opr.op[0]) != ex(p->opr.op[1]);
                case EQ:    return ex(p->opr.op[0]) == ex(p->opr.op[1]);
            }
    }
    return 0;
}
```

Compiler

```
#include <stdio.h>
#include "calc3.h"
#include "y.tab.h"

static int lbl;

int ex(nodeType *p) {
    int lbl1, lbl2;

    if (!p) return 0;
    switch(p->type) {
    case typeCon:
        printf("\tpush\t%d\n", p->con.value);
        break;
    case typeId:
        printf("\tpush\t%c\n", p->id.i + 'a');
        break;
    case typeOpr:
        switch(p->opr.oper) {
        case WHILE:
            printf("L%03d:\n", lbl1 = lbl++);
            ex(p->opr.op[0]);
            printf("\tjz\tL%03d\n", lbl2 = lbl++);
            ex(p->opr.op[1]);
            printf("\tjmp\tL%03d\n", lbl1);
            printf("L%03d:\n", lbl2);
            break;
        case IF:
            ex(p->opr.op[0]);
            if (p->opr.nops > 2) {
                /* if else */
                printf("\tjz\tL%03d\n", lbl1 = lbl++);
                ex(p->opr.op[1]);
                printf("\tjmp\tL%03d\n", lbl2 = lbl++);
                printf("L%03d:\n", lbl1);
                ex(p->opr.op[2]);
                printf("L%03d:\n", lbl2);
            } else {
                /* if */
                printf("\tjz\tL%03d\n", lbl1 = lbl++);
                ex(p->opr.op[1]);
                printf("L%03d:\n", lbl1);
            }
            break;
        case PRINT:
            ex(p->opr.op[0]);
            printf("\tprint\n");
            break;
        }
```

```

case '=':
    ex(p->opr.op[1]);
    printf("\tpop\t%c\n", p->opr.op[0]->id.i + 'a');
    break;
case UMINUS:
    ex(p->opr.op[0]);
    printf("\tneg\n");
    break;
default:
    ex(p->opr.op[0]);
    ex(p->opr.op[1]);
    switch(p->opr.oper) {
    case '+': printf("\tadd\n"); break;
    case '-': printf("\tsub\n"); break;
    case '*': printf("\tmul\n"); break;
    case '/': printf("\tdiv\n"); break;
    case '<': printf("\tcompLT\n"); break;
    case '>': printf("\tcompGT\n"); break;
    case GE: printf("\tcompGE\n"); break;
    case LE: printf("\tcompLE\n"); break;
    case NE: printf("\tcompNE\n"); break;
    case EQ: printf("\tcompEQ\n"); break;
    }
    }
}
return 0;
}

```

Graph

```
/* source code courtesy of Frank Thomas Braun */

#include <stdio.h>
#include <stdarg.h>
#include <string.h>

#include "calc3.h"
#include "y.tab.h"

int del = 1; /* distance of graph columns */
int eps = 3; /* distance of graph lines */

/* interface for drawing (can be replaced by "real" graphic using GD or
other) */
void graphInit (void);
void graphFinish();
void graphBox (char *s, int *w, int *h);
void graphDrawBox (char *s, int c, int l);
void graphDrawArrow (int c1, int l1, int c2, int l2);

/* recursive drawing of the syntax tree */
void exNode (nodeType *p, int c, int l, int *ce, int *cm);

/*****/

/* main entry point of the manipulation of the syntax tree */
int ex (nodeType *p) {
    int rte, rtm;

    graphInit ();
    exNode (p, 0, 0, &rte, &rtm);
    graphFinish();
    return 0;
}

/*c----cm---ce---->          drawing of leaf-nodes
l leaf-info
*/

/*c-----cm-----ce----> drawing of non-leaf-nodes
l
*          node-info
*          |
*  -----
*  |         |         |         |
*  v         v         ...      v
* child1  child2  ...      child-n
*         che     che         che
*cs      cs      cs         cs
*
*/
```

```

void exNode
(
    nodeType *p,
    int c, int l,          /* start column and line of node */
    int *ce, int *cm      /* resulting end column and mid of node */
)
{
    int w, h;             /* node width and height */
    char *s;              /* node text */
    int cbar;             /* "real" start column of node (centred above subnodes)
*/
    int k;                /* child number */
    int che, chm;         /* end column and mid of children */
    int cs;               /* start column of children */
    char word[20];        /* extended node text */

    if (!p) return;

    strcpy (word, "???"); /* should never appear */
    s = word;
    switch(p->type) {
        case typeCon: sprintf (word, "c(%d)", p->con.value); break;
        case typeId:  sprintf (word, "id(%c)", p->id.i + 'A'); break;
        case typeOpr:
            switch(p->opr.oper){
                case WHILE:    s = "while"; break;
                case IF:       s = "if";    break;
                case PRINT:    s = "print"; break;
                case ';':      s = "[;]";   break;
                case '=':      s = "[=]";   break;
                case UMINUS:   s = "[_]";   break;
                case '+':      s = "[+]";   break;
                case '-':      s = "[-]";   break;
                case '*':      s = "[*]";   break;
                case '/':      s = "[/]";   break;
                case '<':      s = "[<]";   break;
                case '>':      s = "[>]";   break;
                case GE:       s = "[>=]"; break;
                case LE:       s = "[<=]"; break;
                case NE:       s = "[!=]";  break;
                case EQ:       s = "[==]";  break;
            }
            break;
    }

    /* construct node text box */
    graphBox (s, &w, &h);
    cbar = c;
    *ce = c + w;
    *cm = c + w / 2;

    /* node is leaf */
    if (p->type == typeCon || p->type == typeId || p->opr.nops == 0) {
        graphDrawBox (s, cbar, l);
        return;
    }
}

```

```

/* node has children */
cs = c;
for (k = 0; k < p->opr.nops; k++) {
    exNode (p->opr.op[k], cs, l+h+eps, &che, &chm);
    cs = che;
}

/* total node width */
if (w < che - c) {
    cbar += (che - c - w) / 2;
    *ce = che;
    *cm = (c + che) / 2;
}

/* draw node */
graphDrawBox (s, cbar, l);

/* draw arrows (not optimal: children are drawn a second time) */
cs = c;
for (k = 0; k < p->opr.nops; k++) {
    exNode (p->opr.op[k], cs, l+h+eps, &che, &chm);
    graphDrawArrow (*cm, l+h, chm, l+h+eps-1);
    cs = che;
}
}

/* interface for drawing */

#define lmax 200
#define cmax 200

char graph[lmax][cmax]; /* array for ASCII-Graphic */
int graphNumber = 0;

void graphTest (int l, int c)
{
    int ok;
    ok = 1;
    if (l < 0) ok = 0;
    if (l >= lmax) ok = 0;
    if (c < 0) ok = 0;
    if (c >= cmax) ok = 0;
    if (ok) return;
    printf ("\n+++error: l=%d, c=%d not in drawing rectangle 0, 0 ... %d,
%d",
        l, c, lmax, cmax);
    exit (1);
}

void graphInit (void) {
    int i, j;
    for (i = 0; i < lmax; i++) {
        for (j = 0; j < cmax; j++) {
            graph[i][j] = ' ';
        }
    }
}
}

```



```

void graphFinish() {
    int i, j;
    for (i = 0; i < lmax; i++) {
        for (j = cmax-1; j > 0 && graph[i][j] == ' '; j--);
        graph[i][cmax-1] = 0;
        if (j < cmax-1) graph[i][j+1] = 0;
        if (graph[i][j] == ' ') graph[i][j] = 0;
    }
    for (i = lmax-1; i > 0 && graph[i][0] == 0; i--);
    printf ("\n\nGraph %d:\n", graphNumber++);
    for (j = 0; j <= i; j++) printf ("\n%s", graph[j]);
    printf("\n");
}

void graphBox (char *s, int *w, int *h) {
    *w = strlen (s) + del;
    *h = 1;
}

void graphDrawBox (char *s, int c, int l) {
    int i;
    graphTest (l, c+strlen(s)-1+del);
    for (i = 0; i < strlen (s); i++) {
        graph[l][c+i+del] = s[i];
    }
}

void graphDrawArrow (int c1, int l1, int c2, int l2) {
    int m;
    graphTest (l1, c1);
    graphTest (l2, c2);
    m = (l1 + l2) / 2;
    while (l1 != m) {
        graph[l1][c1] = '|'; if (l1 < l2) l1++; else l1--;
    }
    while (c1 != c2) {
        graph[l1][c1] = '-'; if (c1 < c2) c1++; else c1--;
    }
    while (l1 != l2) {
        graph[l1][c1] = '|'; if (l1 < l2) l1++; else l1--;
    }
    graph[l1][c1] = '|';
}

```

More Lex

Strings

Quoted strings frequently appear in programming languages. Here is one way to match a string in lex:

```
%{
    char *yylval;
    #include <string.h>
}%
%%
\"[^\"\\n]*[\"\\n] {
    yyval = strdup(yytext+1);
    if (yyval[yyvaleng-2] != '')
        warning("improperly terminated string");
    else
        yyval[yyvaleng-2] = 0;
    printf("found '%s'\n", yyval);
}
```

The above example ensures that strings don't cross line boundaries and removes enclosing quotes. If we wish to add escape sequences, such as `\n` or `\t`, start states simplify matters:

```
%{
    char buf[100];
    char *s;
}%
%x STRING
%%
\"          { BEGIN STRING; s = buf; }
<STRING>\\n { *s++ = '\\n'; }
<STRING>\\t { *s++ = '\\t'; }
<STRING>\\\" { *s++ = '\\\"'; }
<STRING>\"   {
    *s = 0;
    BEGIN 0;
    printf("found '%s'\n", buf);
}
<STRING>\\n { printf("invalid string"); exit(1); }
<STRING>.  { *s++ = *yytext; }
```

Exclusive start state **STRING** is defined in the definition section. When the scanner detects a quote the **BEGIN** macro shifts lex into the **STRING** state. Lex stays in the **STRING** state and recognizes only patterns that begin with **<STRING>** until another **BEGIN** is executed. Thus we have a mini-environment for scanning strings. When the trailing quote is recognized we switch back to initial state 0.

Reserved Words

If your program has a large collection of reserved words it is more efficient to let lex simply match a string and determine in your own code whether it is a variable or reserved word. For example, instead of coding

```

"if"          return IF;
"then"        return THEN;
"else"        return ELSE;

{letter}({letter}|{digit})* {
    yylval.id = symLookup(yytext);
    return IDENTIFIER;
}

```

where **symLookup** returns an index into the symbol table, it is better to detect reserved words and identifiers simultaneously, as follows:

```

{letter}({letter}|{digit})* {
    int i;

    if ((i = resWord(yytext)) != 0)
        return (i);
    yylval.id = symLookup(yytext);
    return (IDENTIFIER);
}

```

This technique significantly reduces the number of states required, and results in smaller scanner tables.

Debugging Lex

Lex has facilities that enable debugging. This feature may vary with different versions of lex so you should consult documentation for details. The code generated by lex in file **lex.yy.c** includes debugging statements that are enabled by specifying command-line option **"-d"**. Debug output in flex (a GNU version of lex) may be toggled on and off by setting **yy_flex_debug**. Output includes the rule applied and corresponding matched text. If you're running lex and yacc together then specify the following in your yacc input file:

```

extern int yy_flex_debug;
int main(void) {
    yy_flex_debug = 1;
    yyparse();
}

```

Alternatively, you may write your own debug code by defining functions that display information for the token value and each variant of the **yylval** union. This is illustrated in the following example. When **DEBUG** is defined the debug functions take effect and a trace of tokens and associated values is displayed.

```

%union {
    int ival;
    ...
};

%{
#ifdef DEBUG
int dbgToken(int tok, char *s) {
    printf("token %s\n", s);
    return tok;
}
int dbgTokenIvalue(int tok, char *s) {

```

```

        printf("token %s (%d)\n", s, yylval.ival);
        return tok;
    }
    #define RETURN(x) return dbgToken(x, #x)
    #define RETURN_ival(x) return dbgTokenIvalue(x, #x)
#else
    #define RETURN(x) return(x)
    #define RETURN_ival(x) return(x)
#endif
%}

%%

[0-9]+      {
              yyval.ival = atoi(yytext);
              RETURN_ival(INTEGER);
            }

"if"        RETURN(IF);
"else"      RETURN(ELSE);

```

More Yacc

Recursion

A list may be specified with left recursion

```

list:
    item
    | list ',' item
    ;

```

or right recursion.

```

list:
    item
    | item ',' list

```

If right recursion is used then all items on the list are pushed on the stack. After the last item is pushed we start reducing. With left recursion we never have more than three terms on the stack since we reduce as we go along. For this reason it is advantageous to use left recursion.

If-Else Ambiguity

A shift-reduce conflict that frequently occurs involves the **if-else** construct. Assume we have the following rules:

```
stmt:
  IF expr stmt
  | IF expr stmt ELSE stmt
  ...
```

and the following state:

```
IF expr stmt IF expr stmt . ELSE stmt
```

We need to decide if we should shift the **ELSE** or reduce the **IF expr stmt** at the top of the stack. If we shift then we have

```
IF expr stmt IF expr stmt . ELSE stmt
IF expr stmt IF expr stmt ELSE . stmt
IF expr stmt IF expr stmt ELSE stmt .
IF expr stmt stmt .
```

where the second **ELSE** is paired with the second **IF**. If we reduce we have

```
IF expr stmt IF expr stmt . ELSE stmt
IF expr stmt stmt . ELSE stmt
IF expr stmt . ELSE stmt
IF expr stmt ELSE . stmt
IF expr stmt ELSE stmt .
```

where the second **ELSE** is paired with the first **IF**. Modern programming languages pair an **ELSE** with the most recent unpaired **IF**. Consequently the former behavior is expected. This works well with yacc because the default behavior, when a shift-reduce conflict is encountered, is to shift.

Although yacc does the right thing it also issues a shift-reduce warning message. To remove the message give **IF-ELSE** a higher precedence than the simple **IF** statement:

```
%nonassoc IFX
%nonassoc ELSE

stmt:
  IF expr stmt %prec IFX
  | IF expr stmt ELSE stmt
```

Error Messages

A nice compiler gives the user meaningful error messages. For example, not much information is conveyed by the following message:

```
syntax error
```

If we track the line number in lex then we can at least give the user a line number:

```
void yyerror(char *s) {
    fprintf(stderr, "line %d: %s\n", yylineno, s);
}
```

When yacc discovers a parsing error the default action is to call **yyerror** and then return from yylex with a return value of one. A more graceful action flushes the input stream to a statement delimiter and continues to scan:

```
stmt:
    ';'
    | expr ';'
    | PRINT expr ';'
    | VARIABLE '=' expr ';'
    | WHILE '(' expr ')' stmt
    | IF '(' expr ')' stmt %prec IFX
    | IF '(' expr ')' stmt ELSE stmt
    | '{' stmt_list '}'
    | error ';'
    | error '}'
;
```

The error token is a special feature of yacc that will match all input until the token following error is found. For this example, when yacc detects an error in a statement it will call **yyerror**, flush input up to the next semicolon or brace, and resume scanning.

Inherited Attributes

The examples so far have used synthesized attributes. At any point in a syntax tree we can determine the attributes of a node based on the attributes of its children. Consider the rule

```
expr: expr '+' expr          { $$ = $1 + $3; }
```

Since we are parsing bottom-up, the values of both operands are available and we can determine the value associated with the left-hand side. An inherited attribute of a node depends on the value of a parent or sibling node. The following grammar defines a C variable declaration:

```
decl: type varlist
type: INT | FLOAT
varlist:
    VAR                      { setType($1, $0); }
    | varlist ',' VAR       { setType($3, $0); }
```

Here is a sample parse:

```
. INT VAR
INT . VAR
type . VAR
type VAR .
type varlist .
decl .
```

When we reduce **VAR** to **varlist** we should annotate the symbol table with the type of the variable. However, the **type** is buried in the stack. This problem is resolved by indexing back into the stack. Recall that **\$1** designates the first term on the right-hand side. We can index backwards, using **\$0**, **\$-1**, and so on. In this case, **\$0** will do just fine. If you need to specify a token type, the syntax is **\$<tokentype>0**, angle brackets included. In this particular example care must be taken to ensure that type always precedes **varlist**.

Embedded Actions

Rules in yacc may contain embedded actions:

```
list: item1 { do_item1($1); } item2 { do_item2($3); } item3
```

Note that the actions take a slot in the stack. As a result **do_item2** must use **\$3** to reference **item2**. Internally this grammar is transformed by yacc into the following:

```
list: item1 _rule01 item2 _rule02 item3
_rule01: { do_item1($0); }
_rule02: { do_item2($0); }
```

Debugging Yacc

Yacc has facilities that enable debugging. This feature may vary with different versions of yacc so be sure to consult documentation for details. The code generated by yacc in file **y.tab.c** includes debugging statements that are enabled by defining **YYDEBUG** and setting it to a non-zero value. This may also be done by specifying command-line option **"-t"**. With **YYDEBUG** properly set, debug output may be toggled on and off by setting **yydebug**. Output includes tokens scanned and shift/reduce actions.

```
%{
#define YYDEBUG 1
}%
...
int main(void) {
    #if YYDEBUG
        yydebug = 1;
    #endif
    yylex();
}
```

In addition, you can dump the parse states by specifying command-line option **"-v"**. States are dumped to file **y.output**, and are often useful when debugging a grammar. Alternatively you can write your own debug code by defining a **TRACE** macro as illustrated below. When **DEBUG** is defined a trace of reductions, by line number, is displayed.

```
%{
#ifdef DEBUG
#define TRACE printf("reduce at line %d\n", __LINE__);
#else
#define TRACE
#endif
}%

statement_list:
    statement
        { TRACE $$ = $1; }
    | statement_list statement
        { TRACE $$ = newNode(';', 2, $1, $2); }
    ;
```

Bibliography

Lesk, M. E. and E. Schmidt [1975]. [Lex – A Lexical Analyzer Generator](#). Computing Science Technical Report No. 39, Bell Laboratories, Murray Hill, New Jersey. A PDF version is available at ePaperPress.

Johnson, Stephen C. [1975]. [Yacc: Yet Another Compiler Compiler](#). Computing Science Technical Report No. 32, Bell Laboratories, Murray hill, New Jersey. A PDF version is available at ePaperPress.

Gardner, Jim, Chris Retterath and Eric Gisin [1988]. MKS Lex & Yacc. Mortice Kern Systems Inc., Waterloo, Ontario, Canada.

Levine, John R., Tony Mason and Doug Brown [1992]. [Lex & Yacc](#). O'Reilly & Associates, Inc. Sebastopol, California.

Aho, Alfred V., Ravi Sethi and Jeffrey D. Ullman [2006]. [Compilers, Principles, Techniques and Tools](#). Addison-Wesley, Reading, Massachusetts.

Paxson, Vern, Will Estes and John Millaway [2015]. [Flex](#). University of California, Berkeley.

Donnelly, Charles and Richard Stallman [2015]. [Bison](#). Free Software Foundation.